

DESIGN NOTES

High Input Voltage Monolithic Switcher Steps Up and Down Using a Single Inductor – Design Note 330A

Jay Celani

Introduction

Ultrawide input voltage requirements are a common design problem for DC/DC converter applications, but when that range includes voltages both above and below the output voltage, the converter must perform both step-up and step-down functions. The LT[®]3433 is a high voltage monolithic DC/DC converter that incorporates two switch elements, allowing for a unique topology that accommodates both step-up and step-down conversion using a single inductor.

The LT3433 uses a 200kHz constant frequency, current mode architecture and operates with input voltages from 4V to 60V. An internal 1% accurate voltage reference allows programming of precision output voltages up to 20V using an external resistor divider. Burst Mode[®] operation improves efficiencies during light-load conditions, reducing the device's quiescent current to 100 μ A during no-load conditions. A soft-start feature reduces output overshoot and inrush currents during start-up, and both current limit foldback and frequency foldback are employed to control inductor current runaway during start-up and short-circuit conditions. The LT3433 is available in a 16-pin fused TSSOP exposed pad package which provides a small footprint and excellent thermal characteristics.

When the converter input voltage is significantly higher than the output voltage, the LT3433 operates as a modified buck converter using a boosted-drive high side switch. If the converter input voltage becomes close enough to the output voltage to require a duty cycle greater than 75% in buck mode, the LT3433 automatically enables a second switch. This second switch pulls the output side of the switched inductor to ground during the “switch on” time, creating a bridged switching configuration.

During bridged switching, the LT3433 merges the elements of buck and boost DC/DC converters as shown in Figure 1. In the simplest terms, a buck DC/DC converter switches the V_{IN} side of the inductor, while a boost converter switches the V_{OUT} side of the inductor. Combining the elements of both topologies achieves both step-up and

step-down functionality using a single inductor, so voltage conversion can continue when V_{IN} approaches or is less than V_{OUT} .

4V-60V Input to 5V Output DC/DC Automotive Converter

A 4V-60V to 5V DC/DC converter is shown in Figure 2. This converter is well suited for 12V automotive battery applications, maintaining output voltage regulation with battery line voltages from 4V cold crank through 60V load dump. The threshold for bridged mode operation is about 8V, so the converter will operate primarily in buck mode except during a cold crank condition. During buck operation, this converter can provide load currents up to 350mA with input voltages up to 60V. Operating with a nominal 13.8V input, this LT3433 converter accommodates loads of 400mA and produces efficiencies up to 82%.

When the input voltage drops below 8V, the converter switches into bridged operation to maintain output voltage regulation. Because the LT3433 switch current limit is

LTC, LT and Burst Mode are registered trademarks of Linear Technology Corporation.

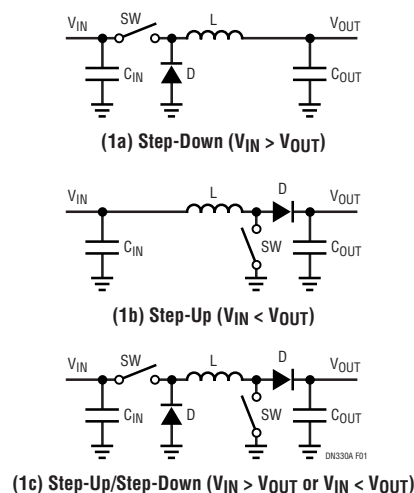

Figure 1. The LT3433 Merges the Elements of Step-Up and Step-Down DC/DC Converters

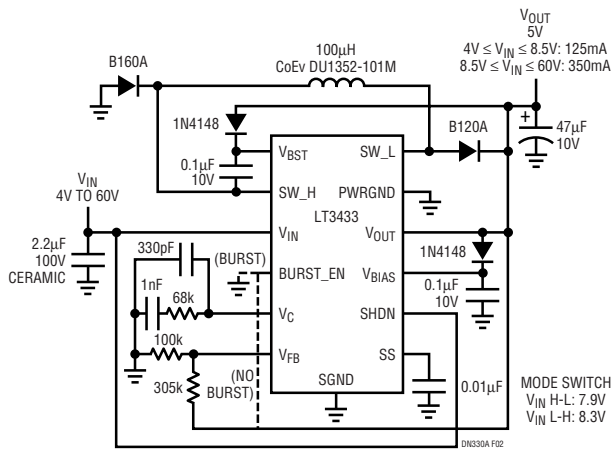

Figure 2. 4V-60V to 5V DC/DC Converter

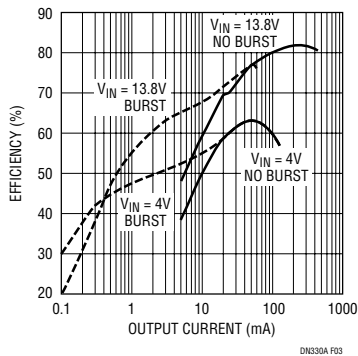

Figure 3. 4V-60V to 5V Conversion Efficiency

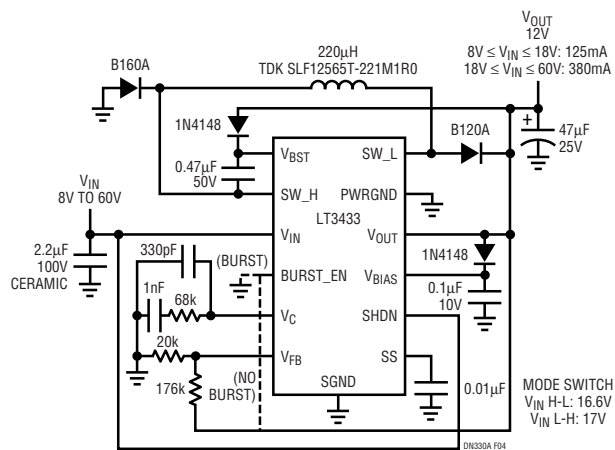

Figure 4. 8V-60V to 12V Converter

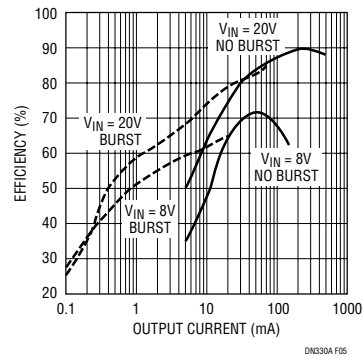

Figure 5. 8V-60V to 12V Conversion Efficiency

fixed, converter load capability is reduced while operating in bridged mode. With an input of 4V, the converter accommodates loads up to 125mA. Not only does this LT3433 converter operate across a large range of DC input voltages, but it also maintains tight output regulation during input transients. When subjected to a 1ms 13.8V to 4V input transition to simulate a cold crank condition, regulation is maintained to 1% with a 125mA load.

8V-60V Input to 12V Output DC/DC Converter

As converter output voltages increase, switch current and duty-cycle limitations prevent operation with V_{IN} at the extreme low end of the LT3433 operational range. The 12V output converter shown in Figure 4 can provide load current up to 125mA with an input voltage as low as 8V. This is suitable for 12V automotive applications without cold-crank requirements, as well as many other

applications such as those powered by inexpensive wall adapters. This converter operates in buck mode with input voltages above 17V, accommodating loads up to 380mA. This converter accommodates loads up to 435mA and produces efficiencies above 89% at 20V input.

Conclusion

The LT3433 simplifies ultrawide input range DC/DC voltage conversion, enabling simple and inexpensive solutions to a variety of design problems. Automatic transitioning between buck and bridged modes of operation provides seamless output regulation for wide input voltage ranges and input voltage transients. The use of a small footprint TSSOP package, a single inductor and few external components reduce board space requirements, increase efficiency and improve thermal characteristics.

Data Sheet Download

<http://www.linear.com/go/dnLT3433>

For applications help,
call (408) 432-1900, Ext. 2759